

Neptune LED UFO Highbay Light



Features

- Light and small UFO structure design, greatly shorten the packing space, save delivery and storage cost
- Use high quality LED and power supply, to ensure the product reliability and life expectancy
- Adopt dust and waterproof structure design, waterproof level IP65
- High lighting efficiency LEDs, lumen efficiency up to 150LM/W of the entire lamp
- Aluminum profile and toughened glass, high impact resistance
- 0-10V dimmable/Dali/Motion Sensor/Daylight Sensor available
- 5 Years Warranty

Application

- Industrial Lighting
- Ceiling Lighting
- Warehouse Lighting
- High/Low Bay Lighting

Technical Features

- Input Voltage: AC100-240V 50/60Hz
- Total Harmonic Distortion: THD: < 10%
- Power Factor: PF>0.95
- Color Rendering Index: Ra>80
- Beam Angle: 60 / 90 / 110 degree
- Lumen maintenance @6000h: >97%
- IP Rating: IP65
- Life Span: >50,000 hours
- Warranty: 5 years
- Material: Aluminum + Optical Glass
- Dimmable: 1-10V / PWM / Resistance / Dali available
- Operation Temperature: -30~+50 celsius degree
- Storage Temperature: -40~+70 celsius degree

Datasheet

Product Code	Rated Power	Input Voltage	LED Type	Driver	LED Qty	Power Factor	Luminous Flux (LM)	Lumen Efficacy (LM/W)	CRI
LGS-UFONP-100W	100W	AC100-240V	Osram SMD2835	SS	210	PF>0.95	15000lm± 10%	150	Ra>80
LGS-UFONP-150W	150W	AC100-240V	Osram SMD2835	SS	300	PF>0.95	22500lm± 10%	150	Ra>80
LGS-UFONP-200W	200W	AC100-240V	Osram SMD2835	SS	420	PF>0.95	30000lm± 10%	150	Ra>80
LGS-UFONP-240W	240W	AC100-240V	Osram SMD2835	SS	420	PF>0.95	36000lm± 10%	150	Ra>80



Installation

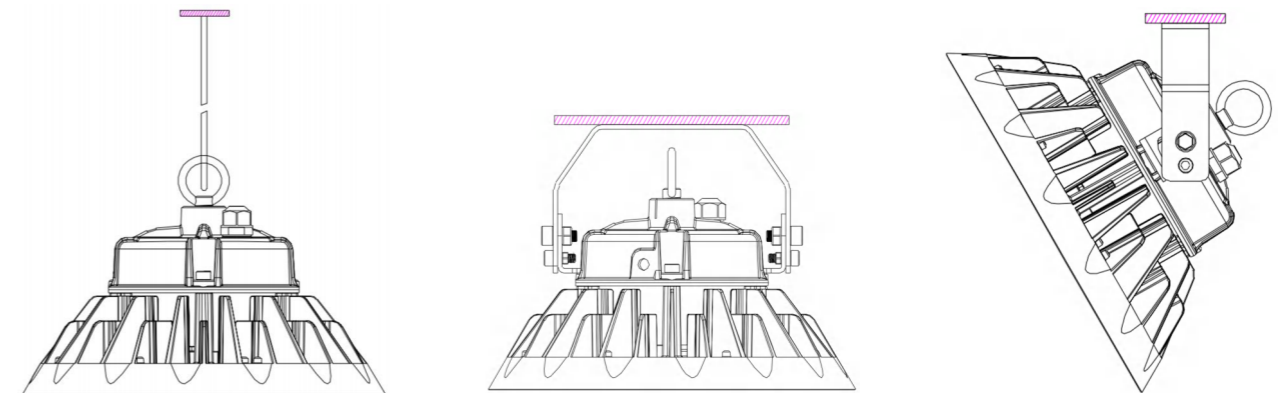

Photometry Curve

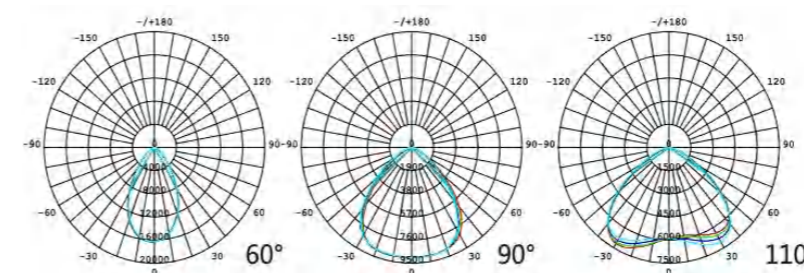

Packing

